

# VOLVO PENTA GENSET ENGINE

# TWD1663GE

PRELIMINARY

685kW (932 hp) Gross kWm at 1800 rpm (standby power without fan)

Emissions Compliance: US Tier 4i (1800rpm)

A powerful, reliable and economical generating set diesel engine built on the dependable Volvo in-line six concept.

## Low cost of ownership

World class fuel efficiency combined with a reliable engine aftertreatment system offers high uptime as well as low cost of ownership. No downtime for regeneration or decreased service intervals compared with competitive products.

## Compact and simple installation

SCR technology selected by Volvo does not increase amount of cooling capacity needed. The result is an engine and aftertreatment system that is easy to install with minor impact on existing installation layout. Installation guidelines as well as drawings and CAD models are easy to access.

## Durability & low noise

Volvo's long experience with SCR systems in combination with base engine development reduces risk of downtime. Well-balanced to produce smooth and vibration free operation with low noise.

## Powerful package

High power density in a compact package with dual stage turbo charging. Excellent load step performance according to ISO 8528-3 G3 governing class.

## Low exhaust emission

Efficient injection as well as robust engine design in combination with SCR technology contributes to excellent combustion and low fuel consumption. TWD1663GE complies with US EPA and CARB Tier 4i emissions.

## Easy service & maintenance

Easily accessible service and maintenance points contribute to the ease of service of the engine.



## Features

- Volvo Penta Electronic management system
- Certified for US/EPA and CARB Tier 4i at 1800 rpm
- High efficient cooling system
- Compact design
- Excellent step load performance acc. to ISO 8528-5 G3 governing class
- Low operating cost
- Water-cooled charge air cooler

## 60 Hz/1800 rpm (with fan)

Prime power			Standby			Generator efficiency (%)
kWm	kWe	kVa	kWm	kWe	kVa	
593	557	697	655	616	770	94%

**VOLVO  
PENTA**

# TWD1663GE

## Technical Data

### General

Engine designation .....	TWD1663GE
No. of cylinders and configuration .....	in-line 6
Method of operation .....	4-stroke
Bore, mm (in.) .....	144 (5.67)
Stroke, mm (in.) .....	165 (6.50)
Displacement, l (in <sup>3</sup> ) .....	16.12 (983.9)
Compression ratio .....	16.5:1
Dry weight, engine only, kg (lb) .....	1700 (3748)
Dry weight with Gen Pac, kg (lb) .....	2200 (4850)

### Performance

**1800 rpm**

with fan, kWm (hp) at:	
Prime Power	593 (806)
Max Standby Power	655 (891)
Fan power consumption, kW (hp)	30 (41)

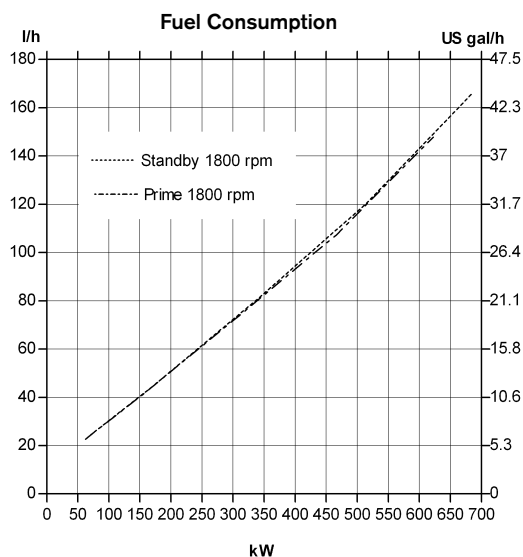

## Dimensions TWD1663GE

Not for installation

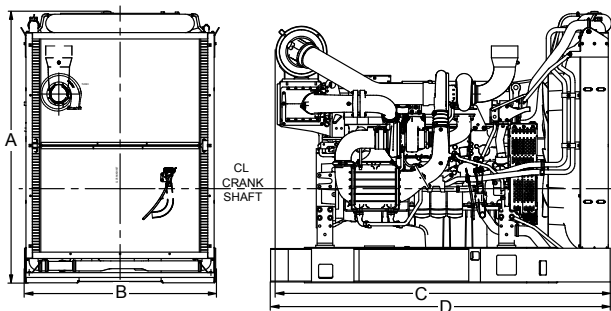

- A\* = 1925 mm / 76 in
  - B\* = 1350 mm / 53.1 in (max width 1401 mm / 55.2 in)
  - C = 2362 mm / 93 in
  - D = 2399 mm / 94.5 in (During transport)
  - D = Max 3255 mm / 128.2 in
- \* Including radiator and intercooler

All specifications are subject to change without notice.  
The engine illustrated may not be entirely identical to production standard engines.

### Power Standards

The engine performance corresponds to ISO 3046, BS 5514 and DIN 6271. The technical data applies to an engine operating on a fuel with calorific value of 42.7 MJ/kg (18360 BTU/lb) and a density of 0.84 kg/liter (7.01 lb/US gal), also where this involves a deviation from the standards. Power output guaranteed within 0 to +2% at rated ambient conditions at delivery. Ratings are based on ISO 8528. Engine speed governing in accordance with ISO 3046/IV, class A1 and ISO 8528-5 class G3

### Rating Guidelines

PRIME POWER rating corresponds to ISO Standard Power for continuous operation. It is applicable for supplying electrical power at variable load for an unlimited number of hours instead of commercially purchased power. A10 % overload capability for governing purpose is available for this rating. STANDBY POWER rating corresponds to ISO Standard Fuel Stop Power. It is applicable for supplying standby electrical power at variable load in areas with well established electrical networks in the event of normal utility power failure. No overload capability is available for this rating.  
1 hp = 1 kW x 1.36

### Information

For more technical data and information, please look in the Generating Set Engines Sales Guide.

## Technical description

### Engine and block

- Cast iron cylinder block with optimum distribution of forces without the block being unnecessarily heavy.
- Wet, replaceable cylinder liners
- Tapered connecting rods for increased piston lifetime
- Crankshaft induction hardened bearing surfaces and fillets with seven bearings for moderate load on main and high-end bearings
- Case hardened and Nitrocarburized transmission gears for heavy duty operation
- Viscous type crankshaft vibration dampers to withstand single bearing alternator torsional vibrations
- Replaceable valve guides and valve seats
- Over head camshaft and 4 valves per cylinder

### Lubrication system

- Full flow oil cooler
- Full flow disposable spin-on oil filter, for extra high filtration
- The lubricating oil level can be measured at start-up

### Fuel system

- Electronic high pressure unit injectors
- Fuel prefilter with water separator and water-in-fuel indicator / alarm
- Fine fuel filter with manual feed pump and fuel pressure switch

### Cooling system

- Efficient cooling with accurate coolant control through a water distribution duct in the cylinder block.
- Belt driven coolant pump with high degree of efficiency
- Water-cooled charge air cooler

### Turbo charger

- Efficient and reliable dual stage turbo chargers
- Intermediate charge air coolers for both turbo chargers
- Waste gate system for the high pressure turbo charger

### Electrical system

- Engine Management System 2 (EMS 2), an electronically controlled processing system which optimizes engine performance. It also includes advanced facilities for diagnostics and fault tracing
- The instruments and controls connect to the engine via the CAN SAE J1939 interface, either through the Control Interface Unit (CIU) or the Digital Control Unit (DCU). The CIU converts the digital CAN bus signal to an analog signal, making it possible to connect a variety of instruments. The DCU is a control panel with display, engine control, monitoring, alarm, parameter setting and diagnostic functions. The DCU also presents error codes in clear text.
- Sensors for oil pressure, oil temp, boost pressure, boost temp, coolant temp, fuel temp, water in fuel, fuel pressure and two speed sensors.

### Engine aftertreatment system

- Emission reduction with SCR technology

## Dimensions SCR Muffler

Not for installation

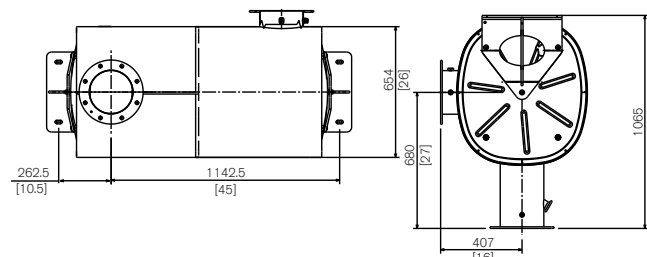

**AB Volvo Penta**  
SE-405 08 Göteborg, Sweden  
www.volvopenta.com